

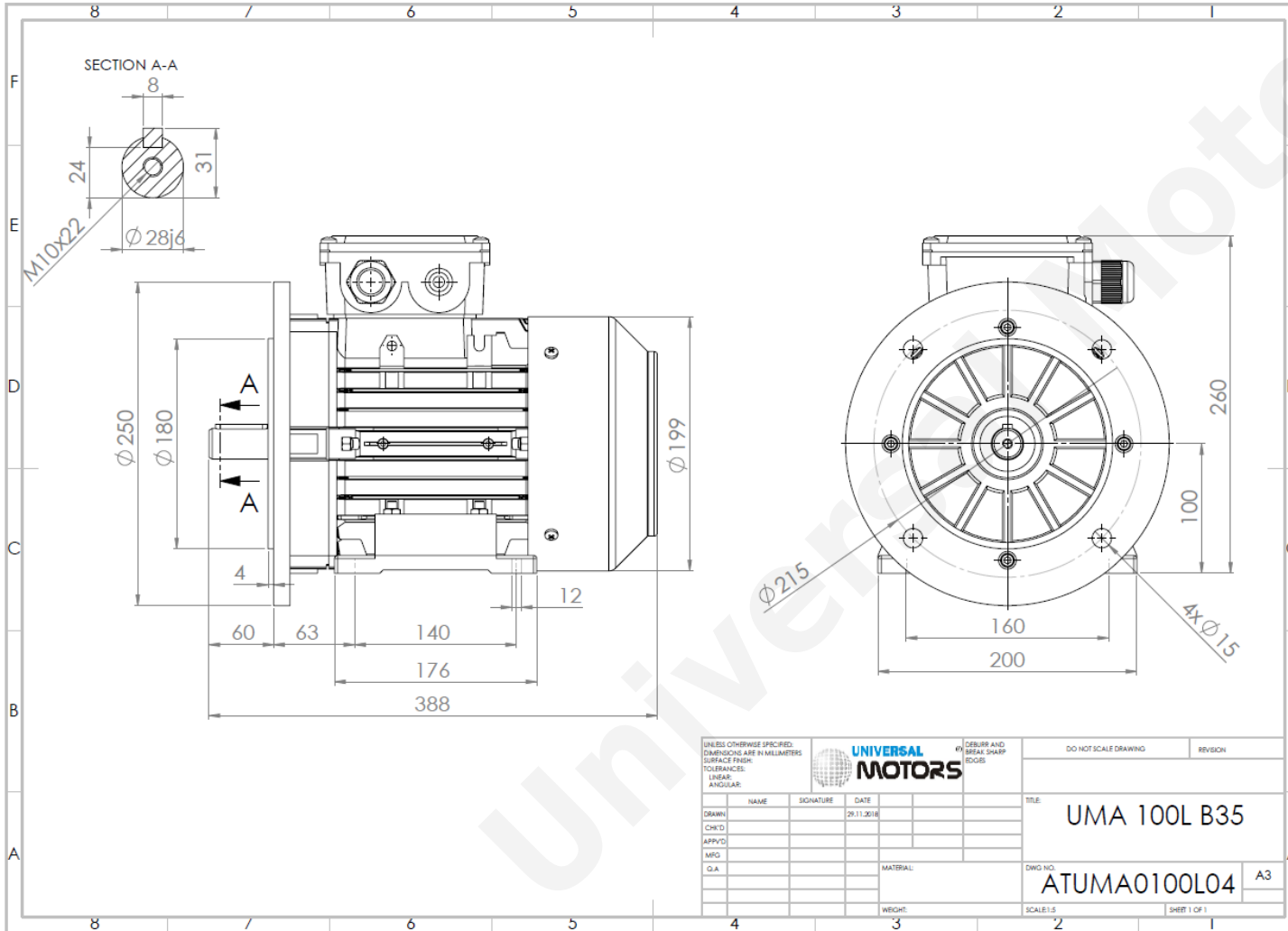

TECHNICAL DATA

Three Phase Electric Motors - Aluminum Frame
 UM3A 100L1-6 IE3
 1.5 kW / 2 Cv
 955 RPM



Motor type:	UM3A 100L1-6 IE3
Output:	1.5 kW / 2 Cv
Speed (min ⁻¹):	955 RPM
Frequency:	50 Hz
Voltage:	400 V
Current:	3.75 A
Power factor (Cos Ø):	0.70
Poles:	6
Insulation class:	F
Temperature rise Class:	B
Efficiency 50%:	81.8 %
Efficiency 75%:	83.0 %
Efficiency 100%:	82.5 %
Torque:	15 N.m
Tstarting/Tnominal:	2.4
Istarting/Inominal:	5.5
Tmaximum/Tnominal:	2.9
Noise:	61 Db(A)
Weight:	22.1 Kg
Brake AC:	AC5
Torque Brake DC:	32 N.m
Bearing DE:	6206 2Z
Bearing NDE:	6206 2Z
Torque Brake AC:	40 N.m
Brake DC:	REB-05-12

Regime - S1

Altitude - 1000m

Environment Temperature - 40°C

CONTACTS:

UNIVERSAL MOTORS Tel: +351 252 299 080
 Rua de São Brás,745 Fax: +351 252 299 089
 4480-782 VILA DO CONDE Mail: geral@universalmotors.pt

* References applied only in the UK